

DESIGN DATA FOR FOLDING STAIRS

FOLDING STAIRS

- Type: FS 1250
 FS 1650
 FS 2050
 FS 2450

- Step width: 800mm (standard)
 Other: (max. 4000 mm)

- In case of deviating dimensions: A = mm
 B = mm
 C = mm

- Operation: Manual
 Pneumatic
 Hydro-pneumatic

- Surface treatment: Hand cleaned + truck primer RAL6018
 Galvanised
 3-layer paint system, colour:

- Option: Locking chain Position detection

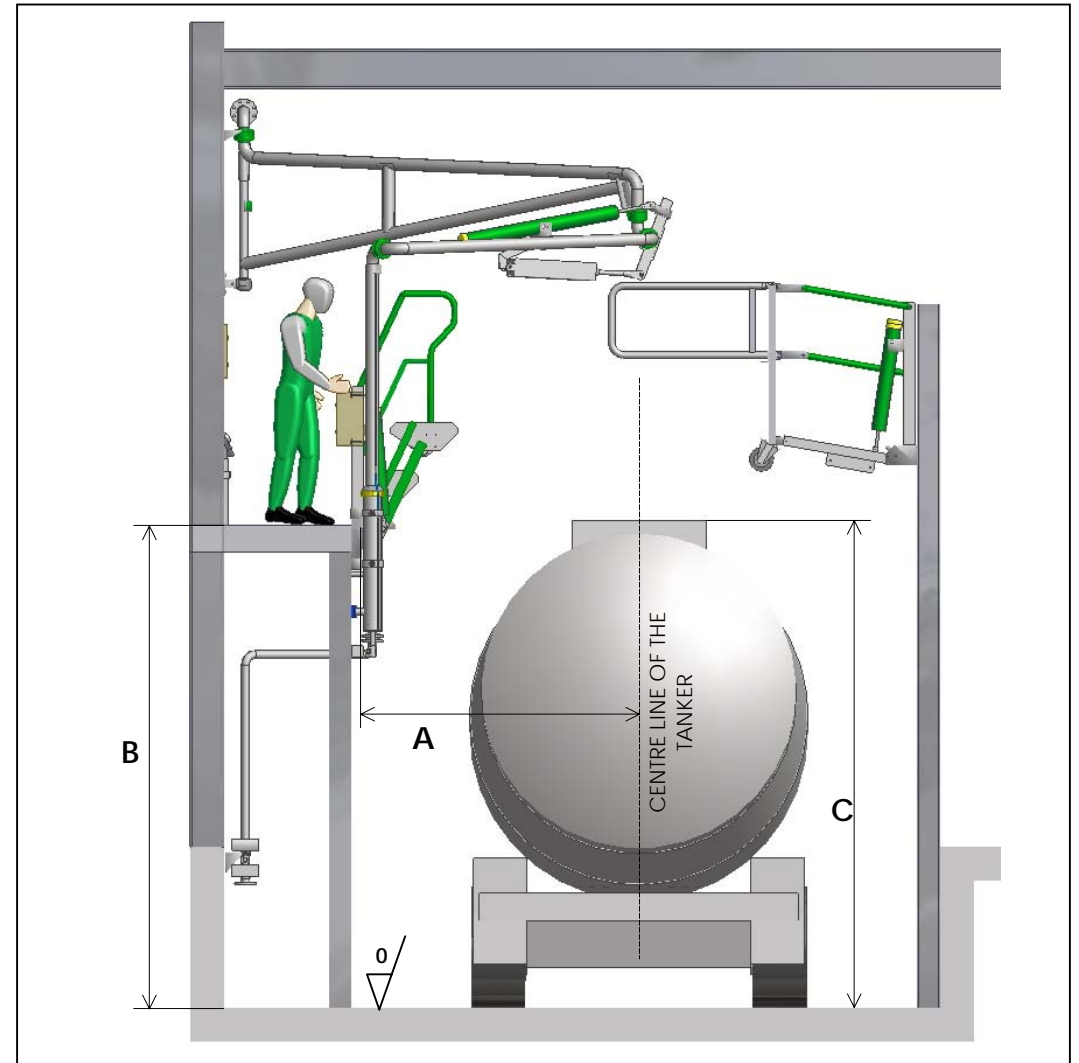
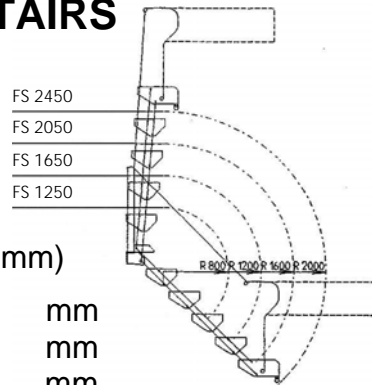

SAFETY CAGES

Dimensions: (depth x width; width max = 12 m)

- 1400 x 1400
 1400 x 2800
 Other:

- Materials: Carbon steel
 Aluminium
 Other:

- Railing: Double all around
 Third railing in front
 Third railing with "V-shape"

- Surface treatment: Same as folding stairs Other:

Additional information and requirements: _____

