



Lending a hand

Robin Boot,
The Netherlands,
Kanon, explains the basic
and symmetric designs
of marine loading arms.

Marine loading arms (MLAs) are used to transfer liquids between a storage facility and a tanker vessel. They consist of an assembly of articulated piping, with particular features and accessories. The design of the MLA is an important factor with regard to the cost of ownership and the convenience of operation.

MLAs with a fully rigid and symmetric design were launched approximately 10 years ago and after having proved their reliability, they are now also available for LNG applications. The symmetric design equally divides the mechanical forces within the MLA structure itself and is especially suited for extraordinary applications like cryogenic purposes, oversized dimensions and mounting on moveable carts and floating jetties.

OCIMF

The articulated piping of which MLAs consist needs to be moved to the ship in an easy and safe way, both up to the extent of the client's wishes. This is an important matter, since detailed knowledge about MLAs is not always available within the buyer's organisation. International guidelines like the Oil Company International Marine Forum (OCIMF) for MLAs are available for that purpose and can safely be used to define specifications with regard to strength calculations, working envelope and accessories.

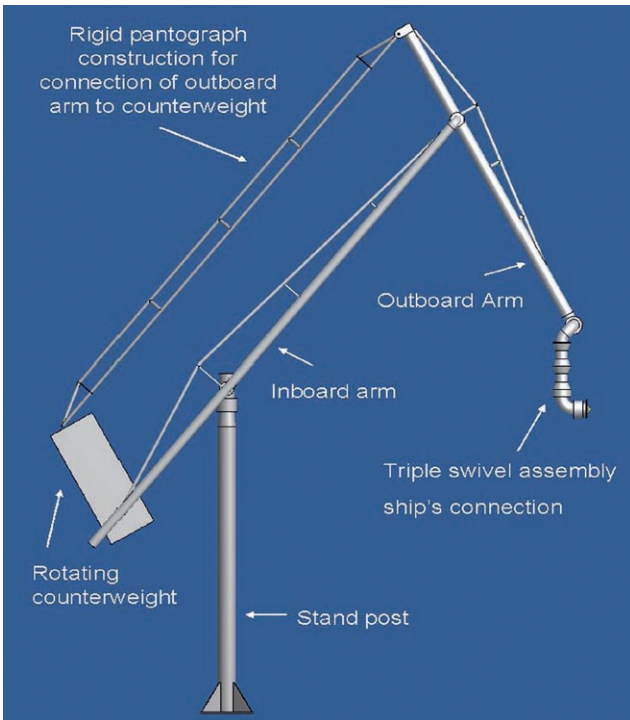

Figure 1. Basic design.

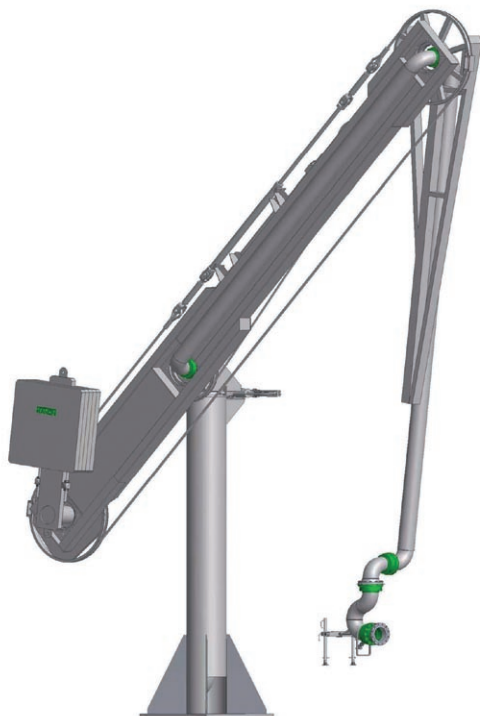

Figure 2. MLA with cable and wheel assembly and support frame.

However, the OCIMF does not describe the different ways of design, even though this is one of the main factors that determines the cost of ownership and convenience in operation. A brief explanation of the basic design of MLAs will help towards fully understanding the symmetric design and its particular advantages.

Basic design of MLAs

Balancing by counterweight

The pipes are arranged as shown in Figure 1 with a stand post, which is a fixed part, and an inboard arm and outboard arm, which are movable parts. As ship tankers may be large and the piping is made of steel with large diameters, the moving parts are very heavy.

With an accurate counterweight balancing, only the weight of the piping and construction steel needs to be brought into motion. For small sized MLAs, manual operation is feasible but wind force can still make operation hard. Large sized MLAs are hydraulically operated.

MLAs can have two separate counterweights, one for the inboard arm and one for the outboard arm, or more efficiently, a single rotating counterweight that is a combination of both. If the counterweight rotates with the outboard arm, the need for an additional counterweight is eliminated, providing a more efficient design. In this case the counterweight is directly connected to the outboard arm and the angular position of the counterweight is parallel to the position of the outboard, like a pantograph. In this way the outboard arm can still move independently from the inboard (Figure 1).

Counterweight connection

The pantograph-like connection between the counterweight and the outboard arm is made either by a cable and wheel assembly (Figure 2) or a rigid connection by means of a steel bar (Figure 1).

Both methods are widely applied. From a maintenance point of view there is an important difference. When looking at the cable system, regular greasing of the cables is essential and the cables themselves are subject to regular inspection and tension adjustments. In case of a fully rigid connection, the balancing is adjusted one time in the factory and never again.

From an efficiency point of view, a loading arm with a rigid connection can be very slim and relatively light, because the pantograph is wider than the cable resulting in a longer counterweight with less weight. This requires a certain amount of free space behind the loading arm. In special cases, when the free space behind the MLA is limited, the counterweight can be made more compact and heavy.

In summary, an MLA with one rotating counterweight and a rigid connection to the outboard arm provides the most reliable and effective solution, resulting in lower weight and less required maintenance.

Different ways to construct the product piping

There are two main categories in which MLAs can be divided; the product piping can be attached to a support frame or it can be self supporting.

Product piping attached to a support frame

The product piping can be supported by a support frame, which offers some flexibility by means of bearings. The support frame bears all the weight of the steel piping of the product line including forces due to wind load, ambient temperature

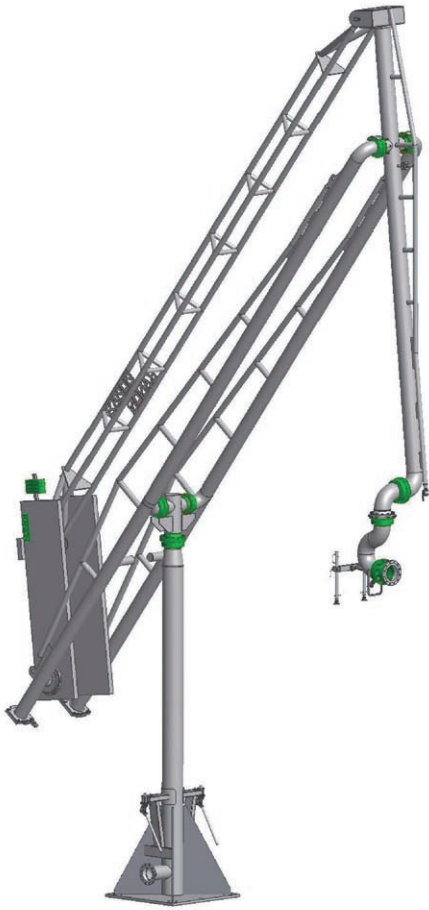

Figure 3. MLA with self supporting piping and symmetric structure.



Figure 4. MLA with support frame and symmetric structure.

and earthquake. The product piping only has to withstand the combination of product temperature and pressure (Figure 2).

This is an original design from the early days of MLA when swivel joints in general could not be made strong enough to support the weight and forces of the construction in combination with the product loads due to pressure and temperature.

Nowadays there are two cases where a support frame is necessary including cryogenic applications such as LNG and aggressive liquids that will heavily corrode the piping.

Self supporting product piping

Improvements in swivel joint design have eliminated the need for a separate support frame, meaning an improvement in efficiency in terms of steel for the support construction and natural resources needed for production of redundant steel, bearings, greasing etc.

When swivel joints are strong enough to take the relevant forces, depending on the product and structure, the product piping can be made self supporting. Any reinforcements will be welded to the product piping to prevent bending and to achieve the required stiffness.

Symmetric design

An MLA with symmetric design has two inboard arms (Figure 3). There are a number of advantages to be noted:

- Almost zero permanent bending moment on the jetty due to dead load moment of the arm, only incidental loads by wind force and earthquake.
- Symmetric loads on swivel joints.
- Symmetric division of forces within the structure.
- Lower weight due to slim design.
- Very large dimensions possible with extended reach and without a huge construction.

The role of swivel joints

As indicated before, the possible design of MLAs relies heavily on the swivel joint performance. With swivel joints strong enough to take all the forces, no separate support structure is needed. And because a symmetric MLA needs two more swivel joints due to the double inboard arm design, the performance must be at a higher level in order to keep the same reliability.

First of all, a high performance swivel does not contain unnecessary replaceable parts, such as replaceable ball races, but it does contain pure materials which are not affected by flame hardening or other treatment which could annul material certificates. Replaceable parts should only include balls, a bit of grease, o-rings to protect the ball races and the main seal. The design should preferably only foresee one dynamic seal face to further minimise wear and chance of leakage. This will result in considerable lower maintenance and higher performance. Also, replaceable swivel joint parts must be designed to last a number of years without the need of replacement, including greasing of ball bearings. When high performance swivel joints are offered, the buyer may request a full two year warranty including parts susceptible to wear and tear. Should any of the replaceable parts need to be replaced, provisions must be taken to make it as simple and quick as possible.

Symmetric MLA for LNG

Until recently, the symmetric design was only available for self bearing product piping, not for a configuration with separate support construction, which is needed for LNG due to the cryogenic environment.

Combining the rigid pantograph connection with a support device including a symmetric construction, a configuration can be achieved where the best features of all are combined.

Figure 4 shows the principle design. The support construction takes over all the structural and geographic related forces and loads, so that the swivel joints only take the loads of the LNG liquid. The support frame is located in the middle of the two inboard arms and supports the outboard arm on two sides.

The requirements of the swivel joints for LNG service have become very stringent in order to minimise the risks of swivel joint failure. In fact, they are required to be suited for much higher forces than required in the practice of transferring LNG.

Swivels which are successfully tested against the prEN1474:2005 norms will definitely lead to an absolute minimum of swivel maintenance. Swivel joints of older types might be field proven, but they would need regular maintenance and may not be able to withstand today's strength testing requirements.

Conclusion

Symmetric MLAs optimise the strength and force division within the loading arm and lead to less weight, slimmer design and the possibility to build MLAs with extended reach and without a large construction. The moments on the jetty are limited to only incidental loads related to wind force and earthquakes.

Developing symmetric MLAs requires high performance swivel joints in order to keep the same reliability. A support construction is only required depending on the physical properties of the products to be transferred e.g. cryogenic or corrosive applications.

The availability of symmetric MLAs for structures with separate support construction is a new development that can also provide the advantages of symmetry to LNG arms. **LNG**



Figure 5. Symmetric design.